

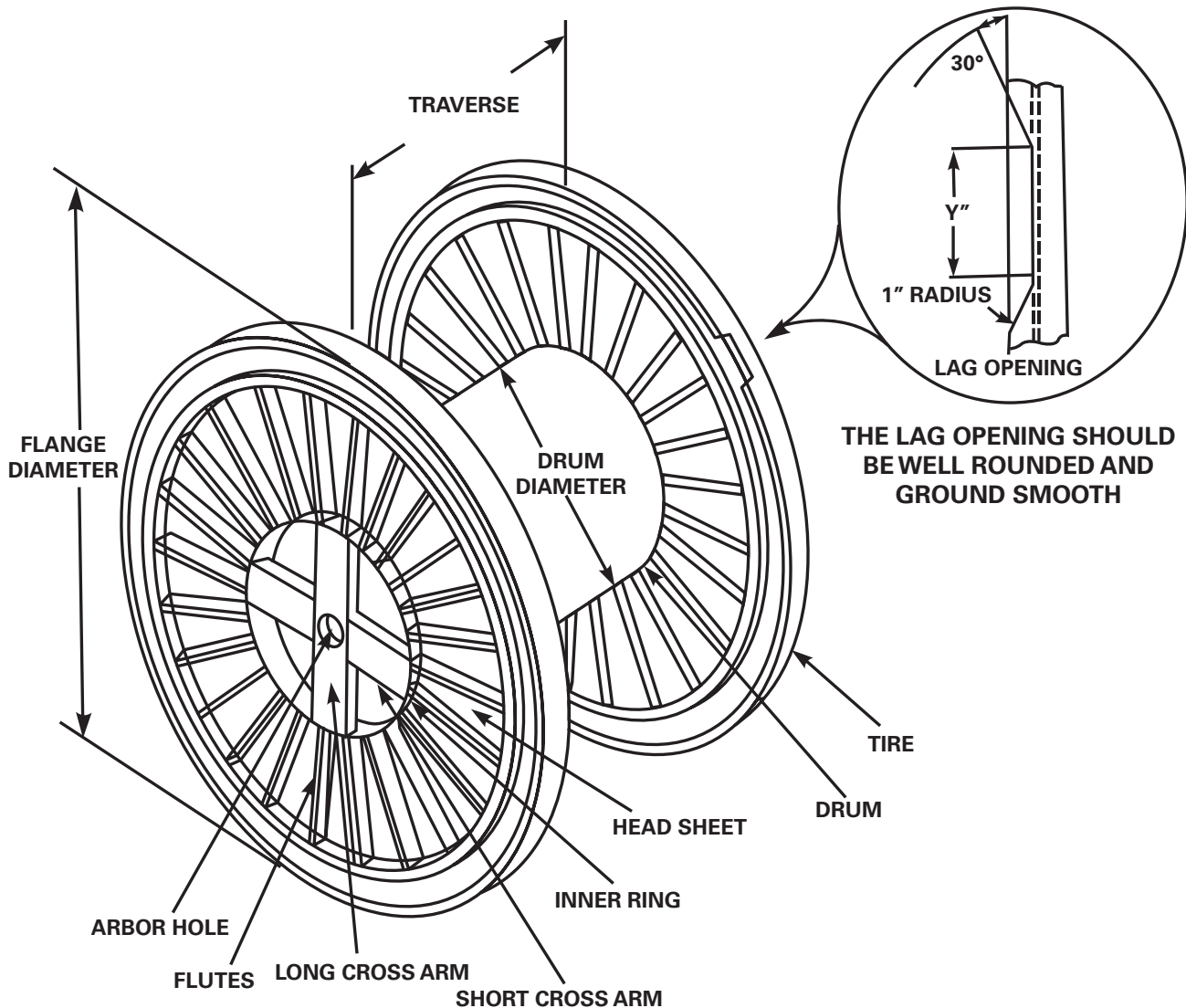

## Steel Reel Specifications



### I-BEAM TIRE FLUTED STEEL REEL—TYPE RMT

*NOTE — When required, cable test hole in the flange shall not have more than 3 flutes removed to provide this opening. The cable test hole shall be reinforced along the cutout with a metal equal to or greater than that required for use in the drum of the reel. Height of cable test hole to be no greater than one-half the length.*





## Steel Reel Specifications

Type*	-Reel Dimensions-			Max. Overall Width (in)	Arbor Hole Diameter (in)	Max. Number of Flutes per Hd	Tire Size (in)	----Cross Arms----			Drum U.S.S. (ga)	Inner Ring Dimensions (in)	(Flange) Head Sheet U.S.S. (ga)	Maximum Capacity---	
	Fl	Trav	Drum					U.S.S. (ga)	Long (in)	Short (in)				(lb)	(kg)
RM	42	24	24	33	3.25	24	2x5/16	8	5x2	4x2	12	3-3/4x3/16	16	1,956	887
RM	48	24	24	33	3.25	24	2x5/16	8	5x2	4x2	12	3-3/4x3/16	16	3,072	1,393
RM	54	32	32	41	3.25	30	2x5/16	8	5x2	4x2	12	3-3/4x3/16	16	4,464	2,024
RM	60	32	32	41	3.25	30	2x5/16	8	5x2	4x2	12	3-3/4x3/16	16	6,360	2,884
RM	66	32	36	41	3.25	32	2-1/2x1/2	8	6x2	5x2	12	3-3/4x3/16	16	7,680	3,482
RM	72	36	40	45	3.25	40	2-1/2x1/2	8	6x2	5x2	12	3-3/4x1/4	16	10,260	4,654
RM	72	36	48	45	3.25	40	2-1/2x1/2	8	6x2	5x2	12	3-3/4x1/4	16	7,872	3,570
RM	78	36	48	45	3.25	40	2-1/2x5/8†	8	6x2	5x2	12	3-3/4x1/4	16	10,752	4,876
RMT	84	36	42	45	5.25	40	7.5lb/ft, 3" I-Beam	8	7-7/8x2	6x2	10	4x1/4	16	13,608	6,171
RMT	84	45	42	55	5.25	40	7.5lb/ft, 3" I-Beam	8	7-7/8x2	6x2	10	4x1/4	16	17,004	7,711
RMT	84	45	56	55	5.25	40	7.5lb/ft, 3" I-Beam	8	7-7/8x2	6x2	10	4x1/4	16	11,196	5,050
RMT	90	45	42	55	5.25	40	7.5lb/ft, 3" I-Beam	8	7-7/8x2	6x2	10	4-1/4x1/4	16	21,036	9,540
RMT	90	45	56	55	5.25	40	7.5lb/ft, 3" I-Beam	8	7-7/8x2	6x2	10	4-1/4x1/4	16	15,216	6,900
RMT	90	54	56	64	5.25	40	7.5lb/ft, 3" I-Beam	8	7-7/8x2	6x2	8	4-1/4x1/4	16	18,252	8,277
RMT	96	60	42	71	5.25	40	7.5lb/ft, 3" I-Beam	8	7-7/8x3	6x3	8	4-1/2x5/16	14	26,000	11,719
RMT	98	60	56	71	5.25	40	7.5lb/ft, 3" I-Beam	8	7-7/8x3	6x3	8	4-1/2x5/16	14	26,000	11,719
RMT**	108	74	56	85	5.25	40	7.5lb/ft, 3" I-Beam	8	7-7/8x3	6x3	8	4-1/2x5/16	14	30,000	13,605

\* RM—Flat bar tire

\*\* Generally used for aluminum wire and cable

† Alternate size is 3x1/2 inch

RMT—I-Beam Tire

NOTE—Tie holes, if necessary, shall be in the flat portion of the head sheet. There will be no holes in the flute itself.

NOTE—A range of 3 to 3.25-inch and 5 to 5.25-inch arbor hole diameter shall be permitted for existing reels until the year 2005.

### WELDING REQUIREMENTS FOR CLASS 1 REELS

Head sheet to tire—at all radii of flute-intermittent weld

Head sheet to inner ring—at all radii of flute-intermittent weld

Drum to inner ring—intermittent weld

Cross arm to cross arm—continuous weld

Cross arm to inner ring—continuous weld

Cross arm to hub—continuous weld

Back-up plate to hub and cross arm—continuous weld

Port frame—continuous weld

All welds shall reflect good welding practice with proper penetration.

